

Data Sheet

Solenoid valve
Type **EV250BW**

Servo operated with assist to open from 0 to 10 bar
for drinking water applications

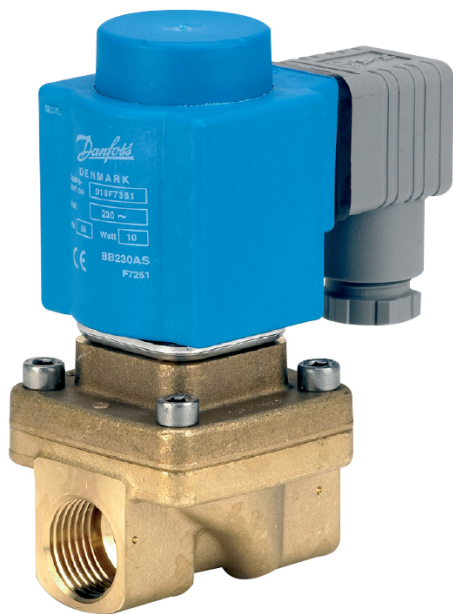

EV250BW 10,12,18 & 22 with assisted lift can operate from 0-10 bar differential pressure. This 2/2-way valve program is especially to use in applications with low differential pressure, but demanding moderate flow rates.



This valve type is designed with EPDM seal, lead free dezincification resistant Eco brass for drinking water applications.

- For water supply
- Houses and large apartments
- Kitchens and bathrooms
- Commercial buildings
- Industrial buildings
- Zoning
- Laundry
- Dishwashing
- Main inlet valves
- Machine and food processing

Features

- Designed for drinking water
- Clip on coil
- Ambient temperature: Up to 50 °C
- Coil enclosure: Up to IP67
- Water hammer damped
- Body material in Eco brass (lead free < 0,1%) and dezincification resistance.
- New generation EPDM sealings recommended for drinking water

1 Portfolio overview

Features	EV250BW NC	EV250BW NO
		
Body material	Eco brass	Eco brass
DN [mm]	10 - 22	10 - 22
Connection	G3/8" - G1"	G3/8" - G1"
Sealing material	EPDM	EPDM
Function	NC	NO
K_v [m³/h]	2.5 - 7	2.5 - 5.2
Differential pressure range [bar]	0 - 10	0 - 10
Temperature range [°C]	0 - 90	0 - 90

2 Function

2.1 Function NC

Coil voltage disconnected (closed)

When the supply voltage to the coil (1) is disconnected, the valve plate (4) is pressed down against the pilot orifice (5) by the closing spring (3). The pressure across the diaphragm (6) is built up via the equalizing orifice (8). The diaphragm closes the main orifice (7) as soon as the pressure across the diaphragm is equivalent to the inlet pressure below, due to the larger diameter of the upper side and/or the tension of the closing spring (3). The valve will be closed as long as the voltage to the coil is disconnected.

Coil voltage connected (open)

When voltage is applied to the coil, the armature (2) and the valve plate (4) are lifted clear of the pilot orifice (5). If there is a differential pressure across the valve, the pressure above the diaphragm (6) drops as the pilot orifice is larger than the equalizing orifice. Therefore the diaphragm is lifted clear of the main orifice (7). If there is no differential pressure across the valve, the armature (2) draws the diaphragm (6) clear of the main orifice (7) using the assisted lift (9). The valve will be open for as long as there is voltage to the coil.

Figure 1: Function NC

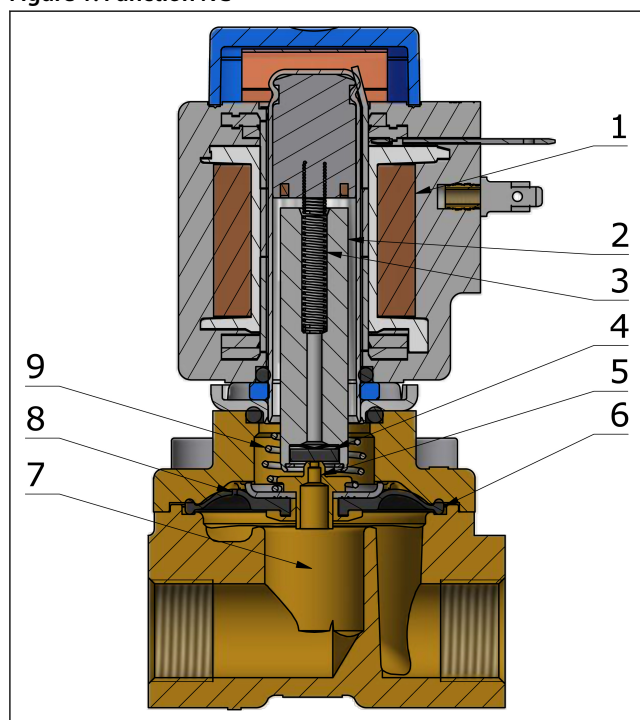

1	Coil
2	Armature
3	Closing spring
4	Valve plate
5	Pilot orifice
6	Diaphragm
7	Main orifice
8	Equalizing orifice
9	Assisted lift

2.2 Function, NO

Coil voltage disconnected (valve is open)

When the supply voltage to the coil (1) is disconnected, the valve plate (7) are lifted clear of the pilot orifice (9) if there is a differential pressure across the valve. The pressure above the diaphragm (10) drops as the pilot orifice is larger than the equalizing orifice. Therefore the diaphragm is lifted clear of the main orifice (12). If there is no differential pressure across the valve, the opening spring (5) draws the diaphragm (10) clear of the main orifice (12) using the assisted lift (8). The valve will be open for as long as there is no voltage to the coil.

Coil voltage connected (valve is closed)

When the supply voltage to the coil (1) is connected, the armature (3) will compress the opening spring (5) and the closing spring will push the spindle (4)/ valve plate down against the pilot orifice (9). The pressure across the diaphragm (10) is built up via the equalising orifice (11). The diaphragm closes the main orifice (12) as soon as the pressure across the diaphragm is equivalent to the inlet pressure below, due to the larger diameter of the upper side and / or the tension of the closing spring (2). The valve will be closed as long as coil voltage is connected

Solenoid valve, Type EV250BW

Figure 2: Function, NO

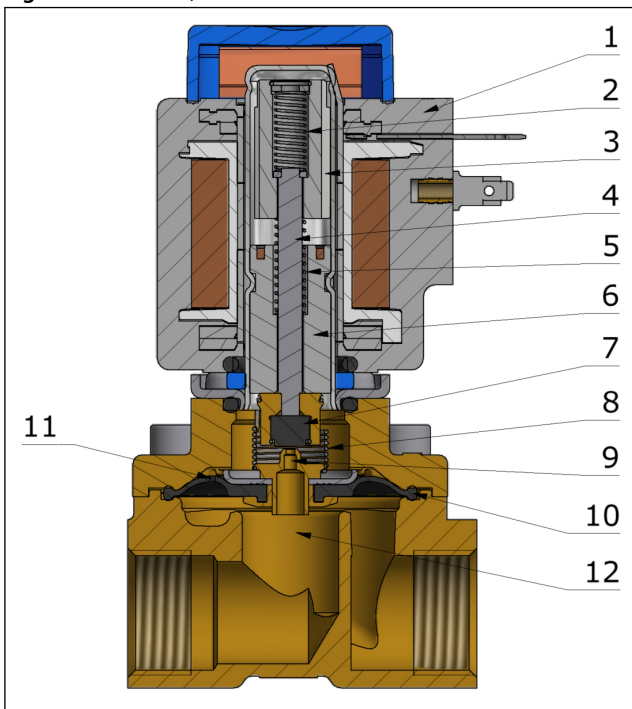

1	Coil
2	Closing spring
3	Armature
4	Spindle
5	Opening spring
6	Armature stop
7	Valve plate
8	Assisted lift
9	Pilot orifice
10	Diaphragm
11	Equalising orifice
12	Main orifice

3 Applications

It is recommended to use a filter in front of the valve. Recommended filter 50 mesh (297 microns).

Figure 3: Filter

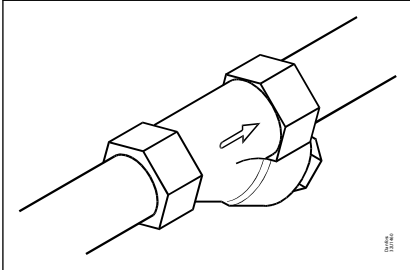

In water applications, exercise the valves at least once every 24 hours, meaning change the state of the valve. The valve exercise will minimize the risk of the valve sticking due to calcium carbonate, zinc or iron oxide build-up.

Figure 4: Exercise: Valve on/off

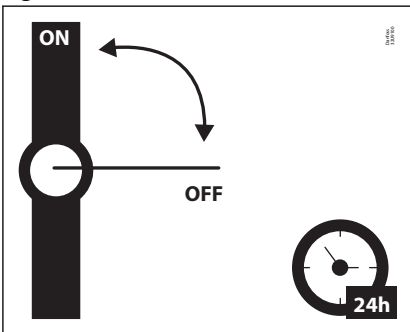

To minimize scaling, and corrosion attack it is recommended that the water passing the valve have the following values:

- Hardness 6-18 °dH to avoid scaling (chalk / lime stone build up).
- Conductivity 50 – 800 µS/cm to avoid brass dezincification and corrosion.
- Above 25°C media temperature avoid stagnant water inside the valve to avoid dezincification and corrosion attack.

Figure 5: Caution: Coil Risk

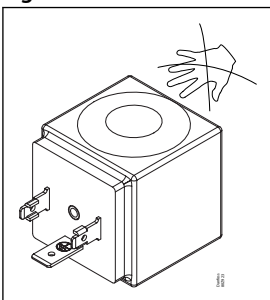

⚠ WARNING:

Risk of burns/fire if used for a continuous power-on time through hot coil surface.

- I Do not touch the coil with bare hands.
- I Keep the coil away from highly flammable substances with low ignition point.

4 Product specification

4.1 Technical data

Table 1: Technical data

Media	EPDM	Drinking water
Media temperature [°C]	EPDM	0 - 90 °C
Ambient temperature [°C]	Up to 50 °C	
K _v value [m ³ /h]	DN10	2.5 m ³ /h
	DN12	4 m ³ /h
	DN18 NC	6 m ³ /h
	DN18 NO	4.9 m ³ /h
	DN22 NC	7 m ³ /h
	DN22 NO	5.2 m ³ /h
Min. Opening differential pressure [bar]	0 bar	
Max. Opening differential pressure [bar]	Up to 10 bar	
Max. working pressure [bar]	Up to 10 bar (Equal to max. differential pressure)	
Max. test pressure [bar]	15 bar	
Viscosity [cSt]	Max. 50 cSt	

Differential pressure range

Table 2: Differential pressure range

Connection ISO228/1	Function	Differential pressure range min. to max. [bar]	
		Coil type	Coil type
		BB AC, BY, BE AC, BG AC/DC, BZ, BO	BB/BE/BY DC
		[Bar]	[Bar]
G3/8-G1	NC	0-10	0-6
	NO	0-10	0-10

Capacity diagram

Example, water: EV250BW 10 NC at 4,5 bar diff. pressure: Approx: 5 m³/h

Figure 6: Capacity diagram

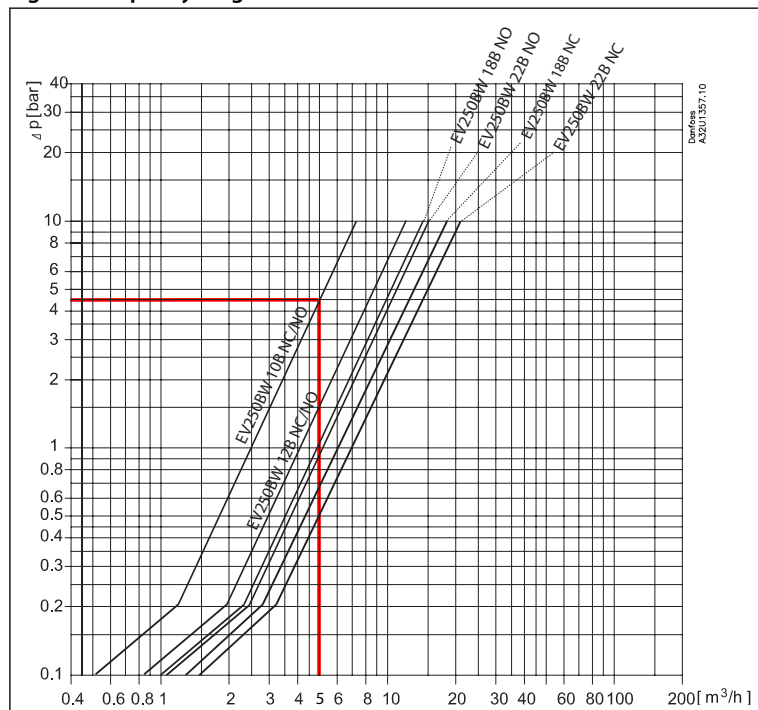

Time to open/close

Table 3: Time to open/close NC and NO

Type	EV250BW 10	EV250BW 12	EV250BW 18	EV250BW 22
Time to open [ms] ⁽¹⁾	100	100	150	150
Time to close [ms] ⁽¹⁾	100	100	100	100

⁽¹⁾ The times are indicative and apply to water. The exact times will depend on the pressure conditions.

Material

Table 4: Material

Components	Materials	Specifications
Valve body/cover	Eco brass	CW724R
Armature/armature stop	Stainless steel	W. no. 1.4105 / AISI 430FR
Armature tube	Stainless steel	W. no. 1.4306 / AISI 304L
Springs	Stainless steel	W. no. 1.4310 / AISI 301
O-ring	EPDM	
Valve plate	EPDM	
Diaphragm	EPDM	

4.2 Dimension and weight

Table 5: Dimension and weight: Eco brass NC and NO

Type	Weight gross valve body without coil	L	B	B ₁ [mm] / Coil type		H	H ₁
	[kg]			[mm]	[mm]		
EV250BW 10	0.6	58	52.3	46	68	91	12.5
EV250BW 12	0.6	58	52.3	46	68	91	12.5
EV250BW 18	0.8	90.5	58	46	68	92	18
EV250BW 22	1.1	90	58	46	68	69.3	22.3

Figure 7: Dimension

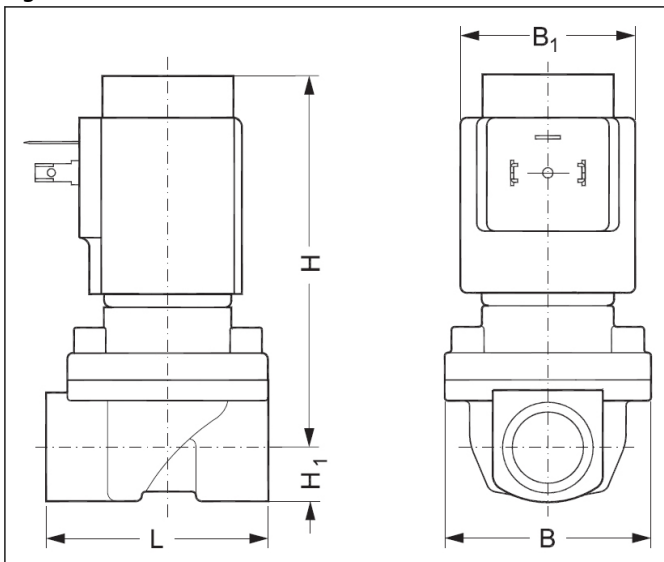

4.3 Mounting

Figure 8: Mounting angle

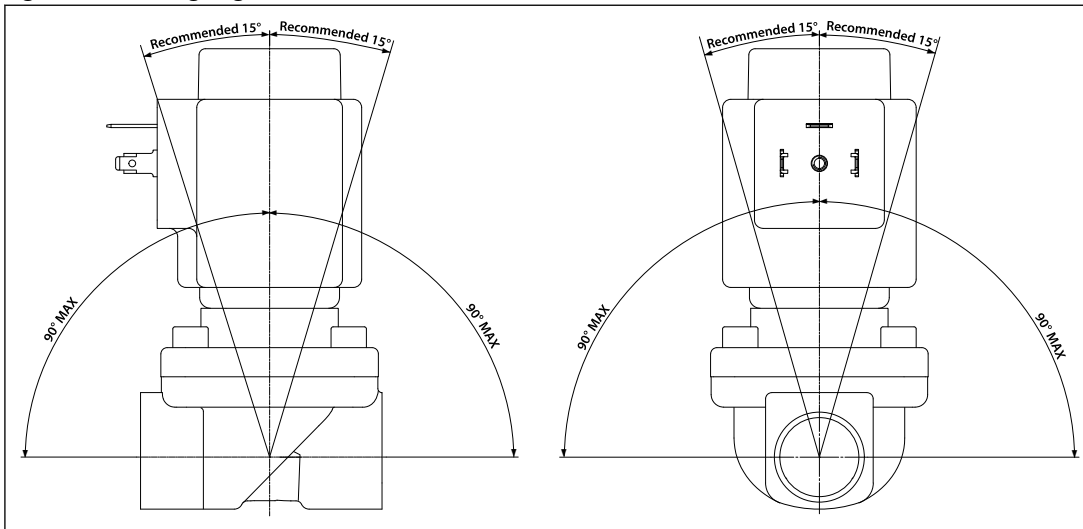

5 Ordering

5.1 Parts program

Table 6: Eco brass, valve body NC and NO

ISO228/1 connection	Orifice	K _v value	Seal material	Function	
	[mm]	[m ³ /h]	EPDM	NC 	NO
G 3/8	10	2.5	EPDM	132U2450	132U2451
G 1/2	12	4	EPDM	132U2452	132U2453
G 3/4	18	6	EPDM	132U2454	
		4.9	EPDM		132U2455
G 1	22	7	EPDM	132U2456	
		5.2	EPDM		132U2457

5.2 Accessories

Coil

Figure 9: BB, clip on



Table 7: BB, clip on

Type	Tambient	Supply voltage	Voltage variation	Frequency	Control	Power consumption		Code no.
	[°C]	[V]		[Hz]		[W]	[VA]	
BB024AS	-40 – 80	24	-15%, +10%	50	NO, NC	11	19	018F7358
BB230AS	-40 – 80	220 - 230	-15%, +10%	50	NO, NC	11	19	018F7351
BB012DS	-40 – 50	12	±10%	DC	NC, NO, UN (Latching)	13		018F7396
BB024DS	-40 – 50	24	±10%	DC	NC, NO, UN (Latching)	16		018F7397

EEC controller and coil unit

Figure 10: EEC controller and coil unit



Table 8: EEC controller and coil unit

Type	Tambient	Supply voltage	Voltage variation	Frequency	Control	Power consumption	Code no.
	[°C]	[V]		[Hz]		[W]	
BE240CS	-25 – 55	208 - 240	±10%	60	NC, NO	4	018F6783
		208 - 240	±10%	50	NC, NO	4	

Solenoid valve, Type EV250BW

Cable plug

Figure 11: Cable plug

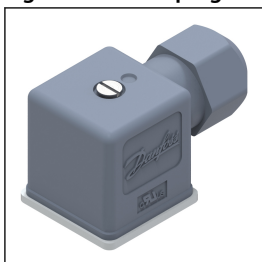

Table 9: Cable plug

Cable plug size	Description	Code no.
DIN 18	Cable plug IP67	042N1256

Universal electronic multi-timer, type ET20M

Figure 12: Type ET20M



Table 10: Type ET20M

Applications	Voltage	To use with coil	Ambient temperature	Code number
	[V AC]		[°C]	
External adjustable timings from 1 to 45 minutes with 1 to 15 seconds drain open. With manual override (test button). Electrical connection DIN 43650 A / EN 175 301-803-A	24 - 240	BB	-10 - 50	042N0185

Spare part kits

Table 11: Spare part kits DN10-22, Eco brass and EPDM sealing

Type	Actuator kit NC	Actuator kit NO
EV250BW DN 10 G 3/8	132U8012	132U8017
EV250BW DN 12 G 1/2	132U8012	132U8017
EV250BW DN 18 G 3/4	132U8018	132U8019

Solenoid valve, Type EV250BW

Type	Actuatorkit NC	Actuator kit NO
EV250BW DN 22 G 1	132U8018	132U8019
	<p>1. O-ring coil 2. 4 x screws 3. Armature tube 4. O-ring 5. 4 x screws for cover 6. Armature + spring 7. Assist Spring 8. Diaphragm</p>	<p>1. O-ring coil 2. 4 x screws 3. Complete NO unit with cover, NO actuator, o-ring, 4 screws, diaphragm, assist spring</p>

6 Certificates, declarations and approvals

6.1 Directives, approvals and certificates

In accordance with

- Low Voltage Directive 2014/35/EU
 - EN60730-1: 2011
 - EN60730-2-8: 2002
- Pressure Equipment Directive 2014/68/E
- RoHS Directive 2011/65/EU
 - Including amendment 2015/863/EU

6.2 Drinking water approvals

Figure 13: Rise



Valves are certified by RISE, notified body 1002. Valid in Denmark and Sweden. In accordance with Boverket Building Regulations (BBR 21, 2014-06-17) Certificate number SCO155-18

Figure 14: SINTEF



Valves are certified by SINTEF. Valid in Norway. In accordance with NKB Product rules nr. 13, pkt. 3.2 – 3.6 :

- NT VVS 100, pkt. 6.4.2 & 6.4.8
- EN ISO 6509

Figure 15: DTI



Inspection by DTI

Figure 16: ACS



Valves are certified by Carso according to ACS guidelines, Circulaire 2002/571.

Figure 17: PZH



Hygienic certificate B-BK-60210-1275/19. Issued by Polish National Institute of Public health (PZH).

Wetted materials in accordance with 4MS (4 member states Germany, Holland, France and UK), DVGW, KTW and W270.

7 Online support

Danfoss offers a wide range of support along with our products, including digital product information, software, mobile apps, and expert guidance. See the possibilities below.

The Danfoss Product Store



The Danfoss Product Store is your one-stop shop for everything product related—no matter where you are in the world or what area of the cooling industry you work in. Get quick access to essential information like product specs, code numbers, technical documentation, certifications, accessories, and more.

Start browsing at store.danfoss.com.

Find technical documentation



Find the technical documentation you need to get your project up and running. Get direct access to our official collection of data sheets, certificates and declarations, manuals and guides, 3D models and drawings, case stories, brochures, and much more.

Start searching now at www.danfoss.com/en/service-and-support/documentation.

Danfoss Learning



Danfoss Learning is a free online learning platform. It features courses and materials specifically designed to help engineers, installers, service technicians, and wholesalers better understand the products, applications, industry topics, and trends that will help you do your job better.

Create your Danfoss Learning account for free at www.danfoss.com/en/service-and-support/learning.

Get local information and support



Local Danfoss websites are the main sources for help and information about our company and products. Find product availability, get the latest regional news, or connect with a nearby expert—all in your own language.

Find your local Danfoss website here: www.danfoss.com/en/choose-region.

Spare Parts



Get access to the Danfoss spare parts and service kit catalog right from your smartphone. The app contains a wide range of components for air conditioning and refrigeration applications, such as valves, strainers, pressure switches, and sensors.

Download the Spare Parts app for free at www.danfoss.com/en/service-and-support/downloads.

Danfoss A/S

Climate Solutions • danfoss.com • +45 7488 2222

Any information, including, but not limited to information on selection of product, its application or use, product design, weight, dimensions, capacity or any other technical data in product manuals, catalogues descriptions, advertisements, etc. and whether made available in writing, orally, electronically, online or via download, shall be considered informative, and is only binding if and to the extent, explicit reference is made in a quotation or order confirmation. Danfoss cannot accept any responsibility for possible errors in catalogues, brochures, videos and other material. Danfoss reserves the right to alter its products without notice. This also applies to products ordered but not delivered provided that such alterations can be made without changes to form, fit or function of the product.

All trademarks in this material are property of Danfoss A/S or Danfoss group companies. Danfoss and the Danfoss logo are trademarks of Danfoss A/S. All rights reserved.