

Data sheet

Butterfly valves with hand lever VFY-WH, VFY-LH

Description



Features:

- Spline driven one piece shaft connected to spherically machined disc allows high torque transmission i.e. quick response and minimum back-lash
- Long term reliability due to upper and lower anti-friction bearings
- Safe maintenance : shaft blow out protection with circlip
- Padlockable hand lever with 10 positions.

Main Data*:

- DN 25 (32)-300
- k_{vs} 40 (62)-5635 m³/h
- PN 16 (10)
- EPDM Liner
- Stainless steel or Ductile iron Epoxy Coated disc
- Medium:
 - Circulation water, drinking water or chilled glycolic water up to 50 %
- Medium temperature:
 - 10 ... 120 °C (EP disc)
 - 10 ... 130 °C (SS disc)
- Wafer or Lug connection
- Approvals: **CE EAC**

** please check the Directive 2014/68/UE table at the end of the data sheet for appropriate product selection*

Ordering

Wafer type **VFY-WH**

	DN	k_{vs} (m ³ /h)	PN	T_{max} (°C)	Disc	Code No.			
		25	40	10	130	Stainless Steel	065B7350		
32/40		62	16	065B7351					
50		79		065B7410					
65		174		065B7411					
80		275		065B7412					
100		496		065B7413					
125		883		065B7414					
150		1212		065B7415					
200		2500		065B7416					
250		3948		065B7337					
300		5635		065B7338					
50		79		16			120	Ductile iron Epoxy Coated	065B8400
65		174							065B8401
80		275							065B8402
100	496	065B8403							
125	883	065B8404							
150	1212	065B8405							
200	2500	065B8406							
250	3948	065B8407							
300	5635	065B8408							

Ordering

Lug type **VFY-LH**

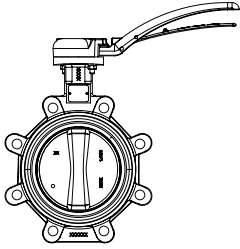
	DN	k_{vs} (m ³ /h)	PN	T _{max} (°C)	Disc	Code No.	
		32	62	16	130	Stainless Steel	065B7365
40		62	065B7366				
50		79	065B7420				
65		174	065B7421				
80		275	065B7422				
100		496	065B7423				
125		883	065B7424				
150		1212	065B7425				
200		2500	065B7436				
250		3948	065B7437				
300		5635	065B7438				
		50	79	16	120	Ductile iron Epoxy Coated	065B8410
		65	174				065B8411
		80	275				065B8412
		100	496				065B8413
		125	883				065B8414
		150	1212				065B8415
		200	2500				065B8416
		250	3948				065B8417
		300	5635				065B8418

Spare parts

Note:
Please contact Danfoss sales to align on details before ordering spare parts.

Replacement Liner **VFY-W Liner**

DN	PN	Liner	Code No.
25	16	EPDM	065B7580
32/40			065B7581
50			065B7582
65			065B7583
80			065B7584
100			065B7585
125			065B7578
150			065B7579
200			065B7592
250			065B7593
300			065B7594
350			065B7591

Replacement Hand lever **VFY-Handle**

for DN	Code No.
25/32/40/50/65/80/100	065B7605
125/150/200	065B7606
250	065B7608
300	065B7609

Technical data

Type		VFY-WH	VFY-LH
Nominal diameter	DN	25-300	32-300
k_{vs} value	m ³ /h	40-5635	62-5635
Rotation angle		90°	
Leakage rate		Acc. to PED 2014/68/EU, EN 12266-1, Rate A ¹⁾	
Nominal pressure	PN	16 (from DN 32-300) / 10 (for DN 25)	16
Medium		Circulation water, Glycolic water up to 50 % or drinking water	
Medium temp.	EP disc	-10 ... 120 (see p-T diagram)	
	SS disc	-10 ... 130 (see p-T diagram)	
Connection		Wafer (centering lugs)	Lug (tapped lugs)
Mounting		Mounting between flanges	Mounting between flanges or mounting deadline
Material			
Body		Cast iron EN GJL 250 (DIN GG25)	Cast iron EN GJL 250 (DIN GG25) DN 32-150 Ductile iron (DIN GGG40) DN 200-300
Disc		Ductile iron EN GJS 400-15 (DIN GGG 40) with Epoxy coating or Stainless Steel	
Shaft		Stainless steel AISI 420	
Liner		EPDM	
Circlip		Steel XC 75 / Stainless steel	
O-ring		Nitrile/Viton	
Upper guide bush		Zinc coated S. + PTFE	
Lower guide bush		Zinc coated S. + PTFE	
Cap		EN GJS-400-15/EN GJL-250	
Hand lever		EN GJS-400-15	

¹⁾ No visible detectable leakage during the testing procedure

Installation positions

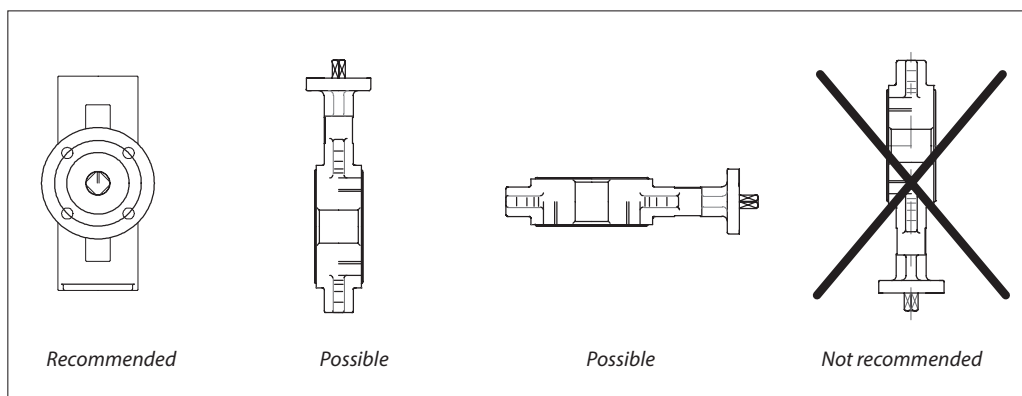

Installation conditions

It is recommended that distances indicated below are respected in order to prolong lifetime of the valve. Mounting the valve close to pipework junctions (turbulent zones) increases wear.

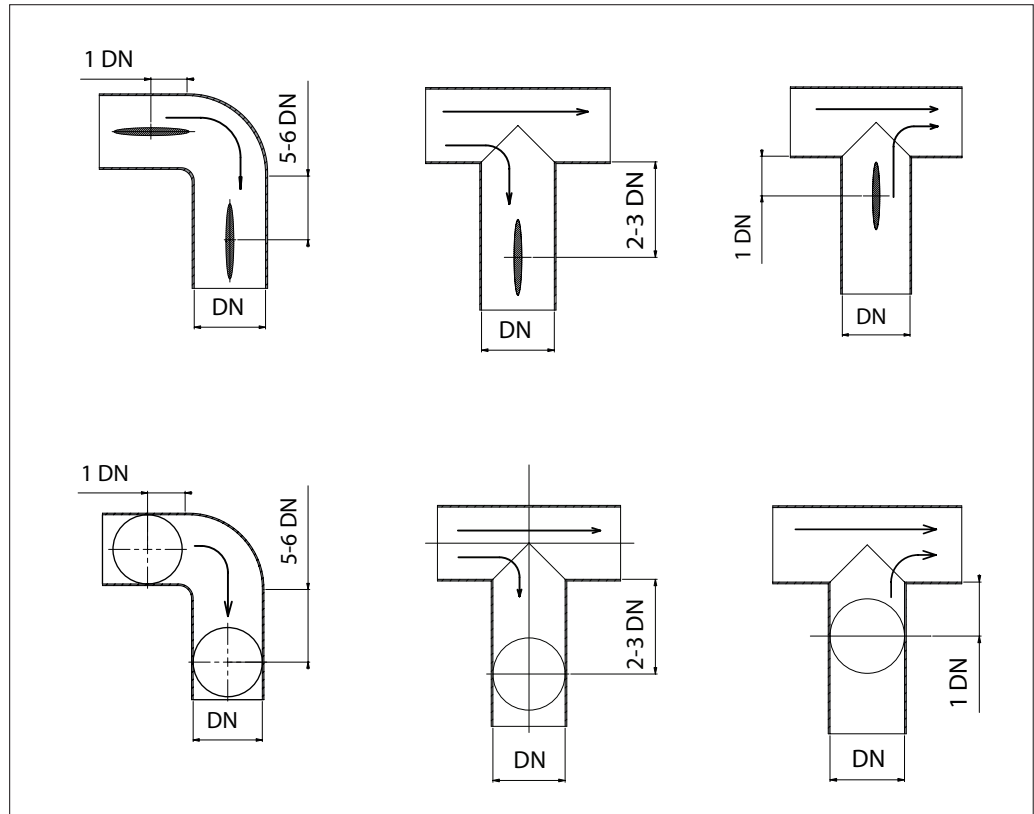

P-T diagram

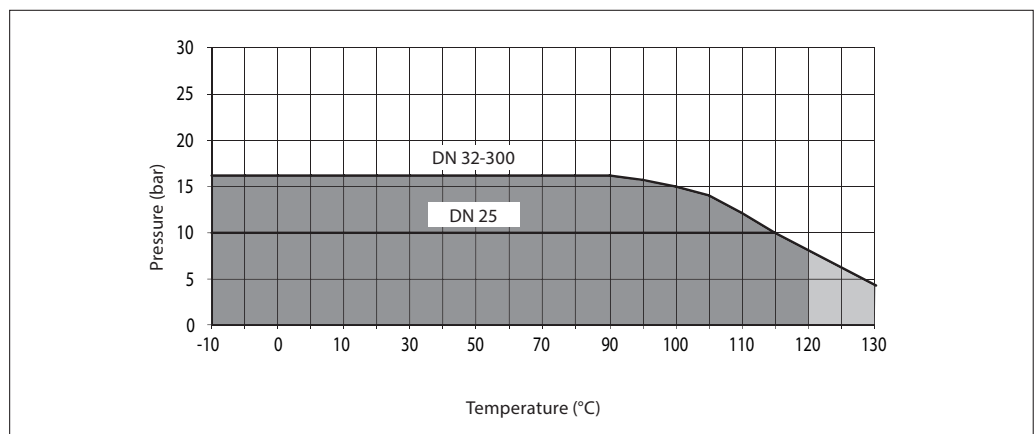

Headloss diagram
For water at 20°C

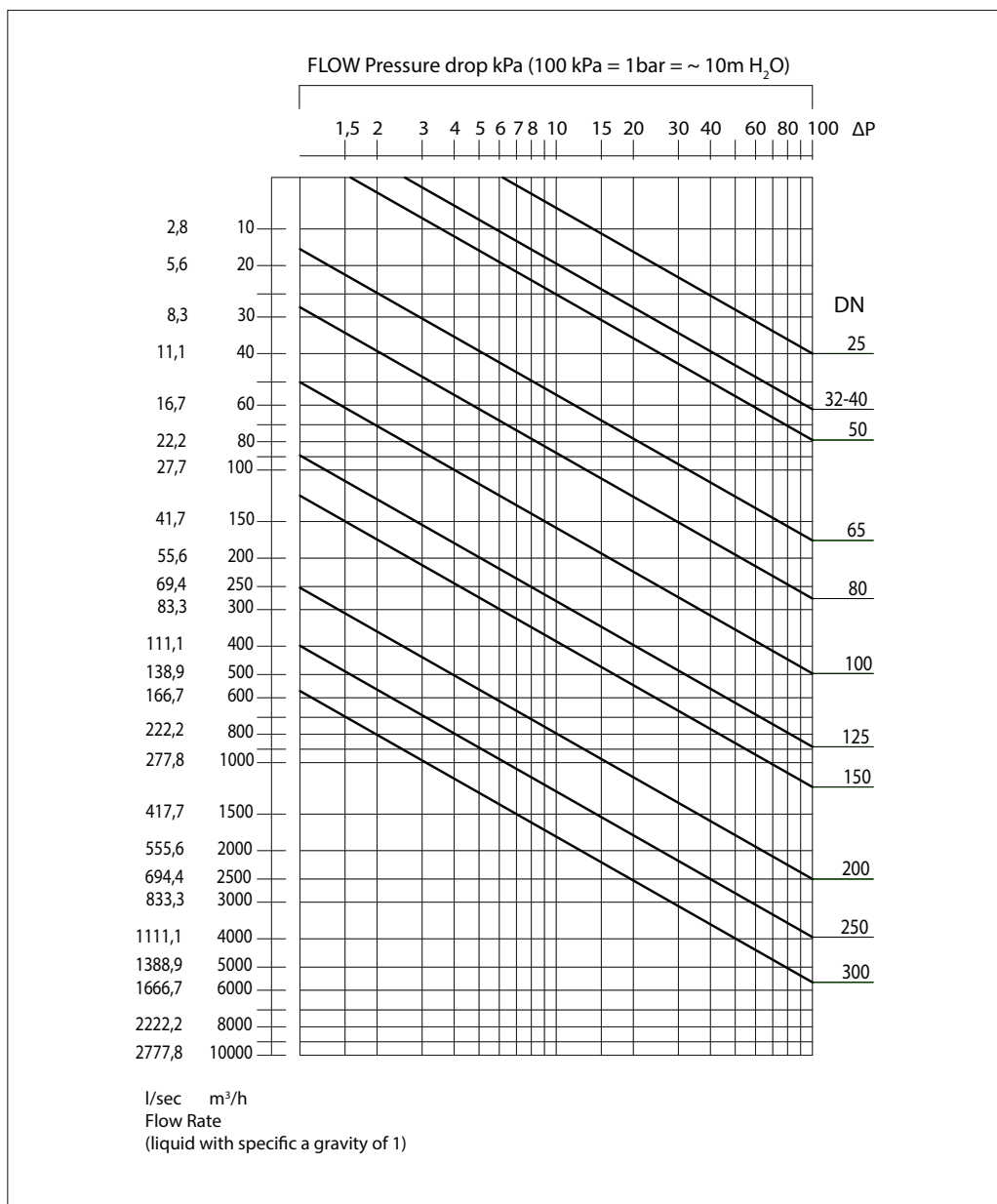

Design

- 1. Body
- 2. Disc
- 3. Shaft
- 4. Liner
- 5. Circlip
- 6. O-ring
- 7. Upper guide bush
- 8. Lower guide bush
- 9. Cap
- 10. Hand lever

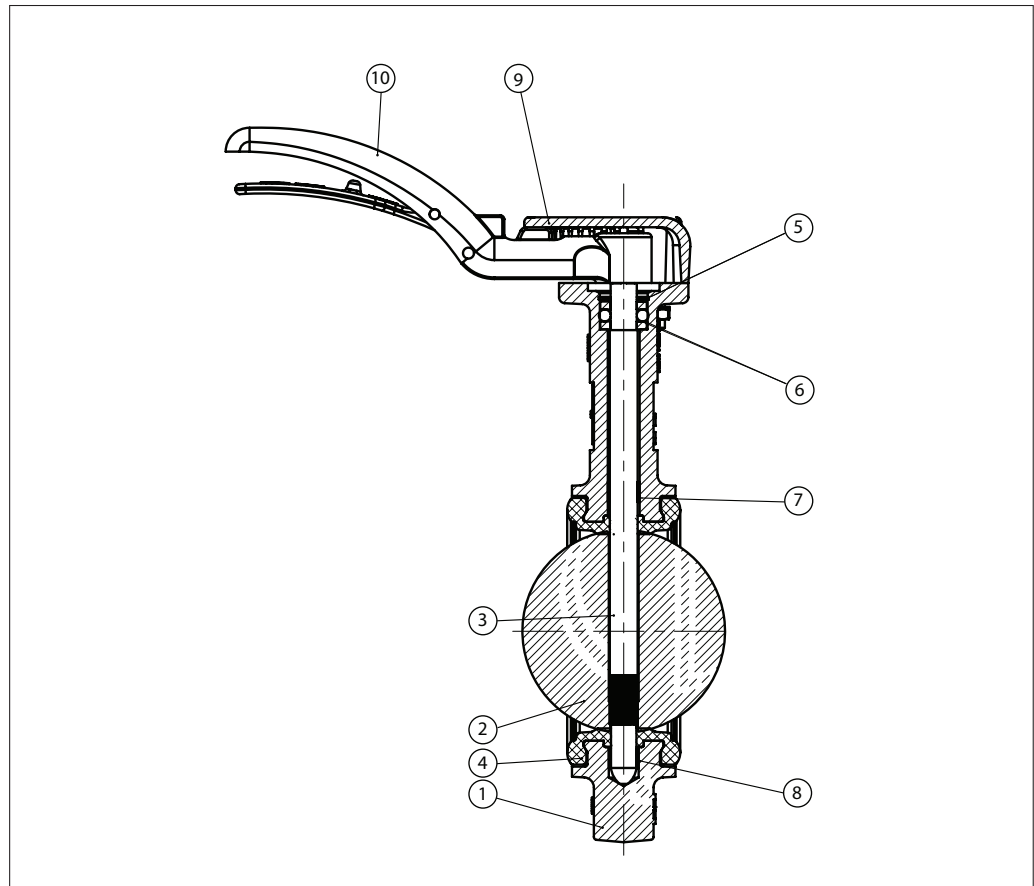

Dimensions

VFY-WH

DN	Ø	A	B	C	D	E	Weight (kg)
							VFY-WH
mm							
25	32	50	158	200	33	45	2.3
32/40	43	57	163	200	33	45	2.4
50	54	62	169	200	43	45	3.3
65	70	70	178	200	46	45	3.6
80	85	89	184	200	46	45	4.0
100	100	106	208	200	52	45	6.3
125	125	120	223	290	56	65	7.5
150	150	131	236	290	56	65	8.5
200	200	165	258	290	60	65	12.2
250	250	196	266	450	68	46	23.7
300	300	238	336	450	79	86	28.2

VFY-LH

DN	Ø	A	B	C	D	E	Weight (kg)
							VFY-LH
mm							
32/40	43	57	163	200	33	45	2.8
50	54	62	169	200	43	45	3.7
65	70	70	178	200	46	45	4.1

DN	Ø	A	B	C	D	E	Weight (kg)
							VFY-LH
mm							
80	85	89	184	200	46	45	5.1
100	100	106	208	290	52	65	7.6
125	125	120	223	290	56	65	10.0
150	150	131	236	290	56	65	11.0
200	200	162	290	290	60	98	17.2

DN	Ø	A	B	C	D	E	Weight (kg)
							VFY-LH
mm							
250	250	198	266	450	68	46	29.8
300	300	227	290	450	77	46	37.6

V.D.090.1/01



Data sheet

VFY-WH, VFY-LH

Directive 2014/68/UE
Equipments under pressure

Products manufactured in conformity with the requirements of the directive, according to pressure, DN and fluid. Relevant for countries following this Directive (ie, PED)

Family	DN (mm)	Cat.	Mounting	PFA	PS				
				water	L1	L2	G1	G2	
VFY DN25 to 350 mm with EPDM liner	10 bar	25 to 100	4§3	Flanges	10	10	10	-	10
				End of line	6	6	6	-	6
	125 to 350	I	Flanges	10	10	10	-	10	
			End of line	6	6	6	-	6	
	16 bar	32 to 100	4§3	Flanges	16	16	16	-	10
				End of line	12	12	12	-	10
		125	I	Flanges	16	16	16	-	10
				End of line	12	12	12	-	10
		150	I	Flanges	16	10	16	-	10
				End of line	12	6	12	-	10
		200 to 300	I	Flanges	16	10	16	-	10
				End of line	10	6	10	-	10
	350	I	Flanges	16	10	16	-	10	
			End of line	8	6	8	-	8	
	20 bar	32 to 250	4§3	Flanges	20	-	20	-	-
				End of line	12	-	12	-	-
		300 to 350	I	Flanges	20	-	20	-	-
				End of line	12	-	12	-	-
25 bar	32 to 150	4§3	Flanges	25	-	25	-	-	
			End of line	16	-	16	-	-	
VFY DN400 to 1200 mm with EPDM liner	10 bar	400 to 1200	I	Flanges	10	10	10	-	-
				End of line	6	6	6	-	-
	16 bar	400 to 1200	I	Flanges	16	-	16	-	-
				End of line	8	-	8	-	-
	20 bar	400 to 600	I	Flanges	20	-	20	-	-
				End of line	10	-	10	-	-
PS: Maximum allowable pressure (bars) in accordance with directive 2014/68/EC PFA: Allowable operating pressure (bars) for supply, distribution and disposal of water				L1: Group 1 liquid - Hazardous fluid category L2: Group 2 liquid - Other fluids G1: Group 1 gas - Hazardous gas category G2: Group 2 gas - Other gasses					

Danfoss A/S

Climate Solutions • danfoss.com • +45 7488 2222

Any information, including, but not limited to information on selection of product, its application or use, product design, weight, dimensions, capacity or any other technical data in product manuals, catalogues descriptions, advertisements, etc. and whether made available in writing, orally, electronically, online or via download, shall be considered informative, and is only binding if and to the extent, explicit reference is made in a quotation or order confirmation. Danfoss cannot accept any responsibility for possible errors in catalogues, brochures, videos and other material. Danfoss reserves the right to alter its products without notice. This also applies to products ordered but not delivered provided that such alterations can be made without changes to form, fit or function of the product.

All trademarks in this material are property of Danfoss A/S or Danfoss group companies. Danfoss and the Danfoss logo are trademarks of Danfoss A/S. All rights reserved.